

Meteor Cutter

It's time to upgrade

Do More. Hear Less. Clean Fast.

The development of hydro cutters has been zero to none for the past 10 years. We decided to act.

The new Meteor from BBM is the result. It is a blade that the market didn't know it would ever need. It is outstanding in its class and master's productivity.

In the new Meteor you get the best raw materials on the market, carefully evaluated geometry allowing for exceptional performance in tough environments.

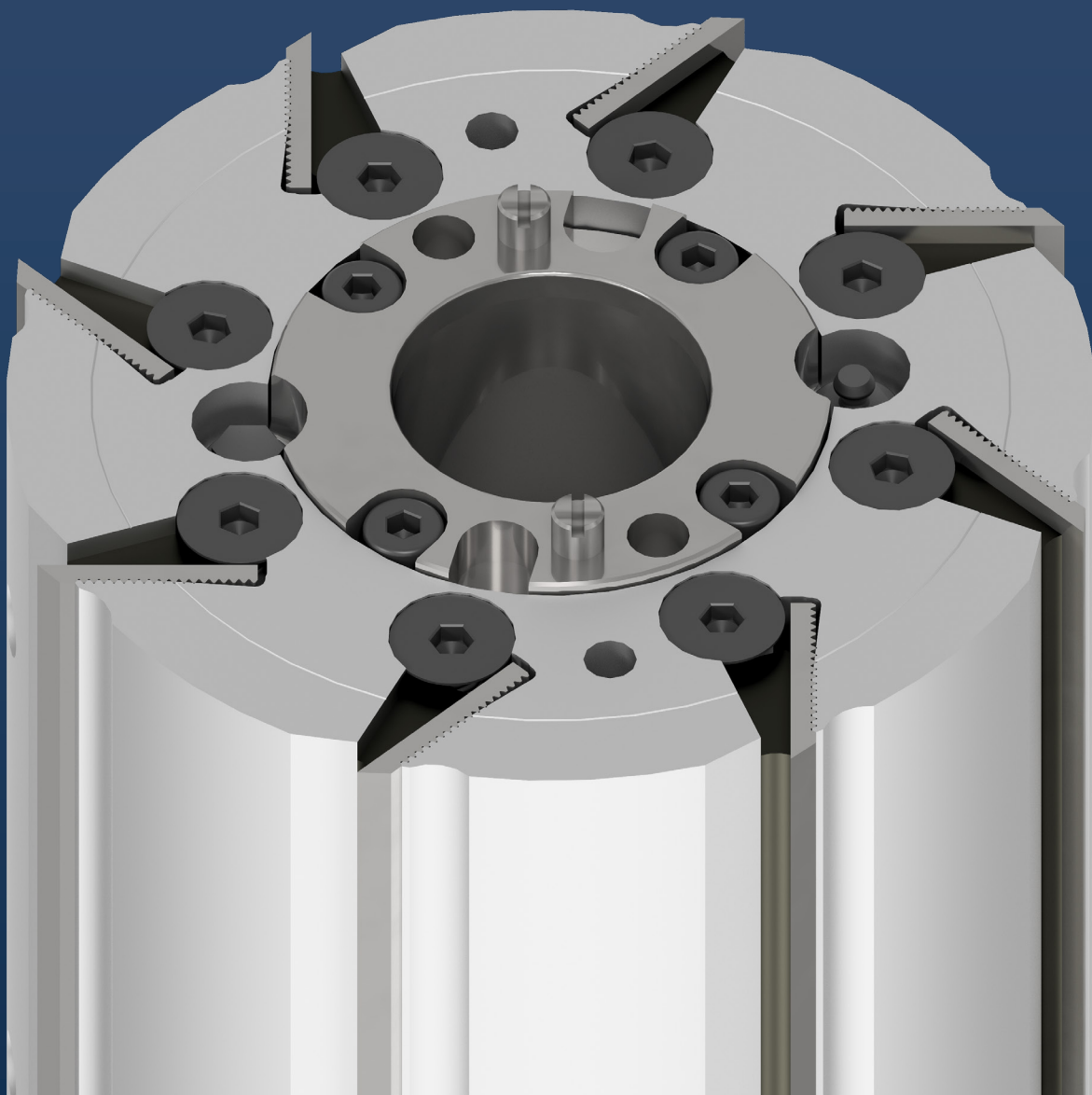

Easy to clean

Due to the flat surface and no peripheral openings. Nowhere for residue to remain.

Reverse angled wedge

Minimizing the risk of the blade coming off when planing.

Corrugated knives

Making the knife very easy to remove, and it always stays straight when tightening the screws.

Reduced noise

Due to the closed design there are no screw holes on the surface of the cutter that causes vortices.

Faster repositioning

Attached with only two clamping screws. Allowing for fast repositioning of knives in service.

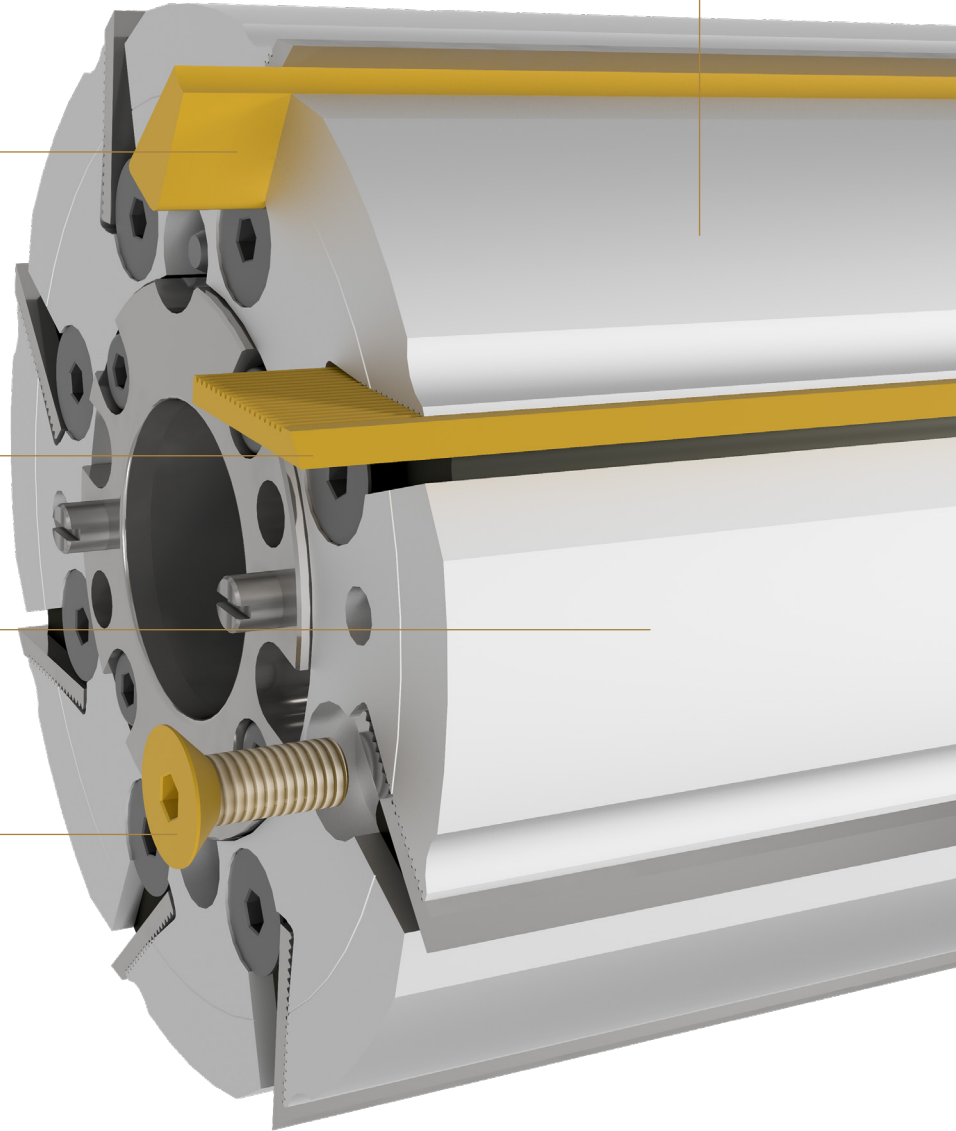

* Can run with both 30 & 35 mm back corrugated 4 mm knives.



Fast change

Less time consuming production stops to change tool.



Safer postings

Due to cut division into smaller cuts, the power needed is reduced. Sustainability at its peak!

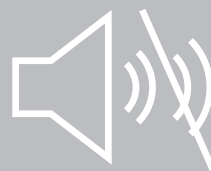

Less noise

The noise from the rotating tool is considerably lower compared to conventional cutter heads due to the closed design.



Easy to clean

Smaller chips that provides denser storage with less air.

Knives

GalaxPro

The premium coated planer knife for challenging conditions and high demands of surface quality and running time.

HSS (Neutral)

Our standard planer knife quality for the wood planing industry. Suitable for standard demands in easy conditions.

x 5
longer running time

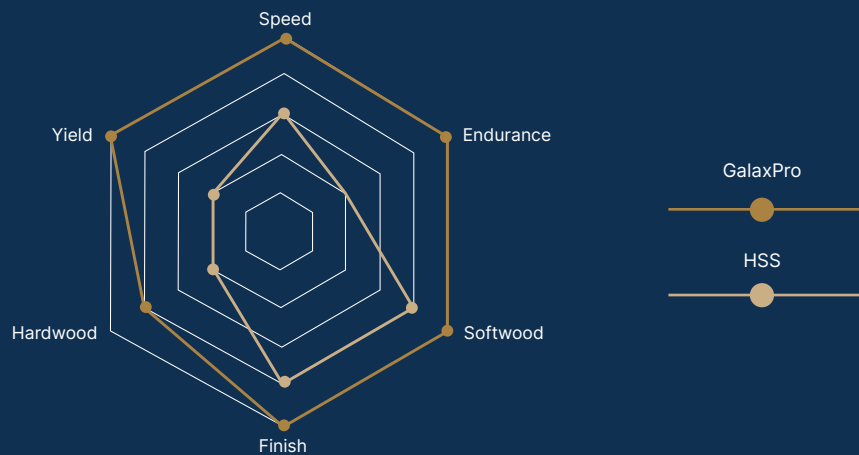

Outstanding durability.

Increased surface quality.

Up to 5 times longer running time compared to HSS.

BBM developed coating.

High quality European steel manufactured with industry leading tolerances.

Available sizes:

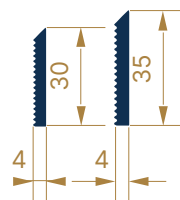

Technical Data

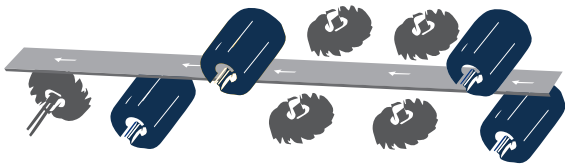

D	D2	B	Z	Bore	RPM
180	172	235	6	**	6000
180	172	235	8	**	6000
203	172	235	8	**	6000
203	195	235	10	**	6000
203	195	235	12	**	6000
203	195	260	10	**	6000
203	195	260	12	**	6000
203	195	260	16	**	6000
250	242	310	16	**	6000
250	242	310	20	**	6000

Torque wrench for planer cutters	Art.No.
Wrench 19-110Nm L385	V745600
Bit holder 1/4 S6mm L=105	V745540
Bit Torx 20 L = 50	V745547

Accessories	Art.No.
Safety ring Ø45 spindle	K32091
Safety ring Ø50 spindle	K32092
Safety ring Ø60 spindle	K32093